



Thermal Vision for a Smarter Planet



What Data We are **Capturing** from our Satellites and its Market

\$700 Billion Space Data could add to the economy by 2030

0.4-0.7 μm



3-14 μm

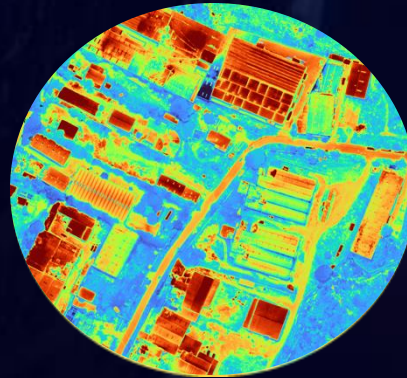

.75 cm-100 cm

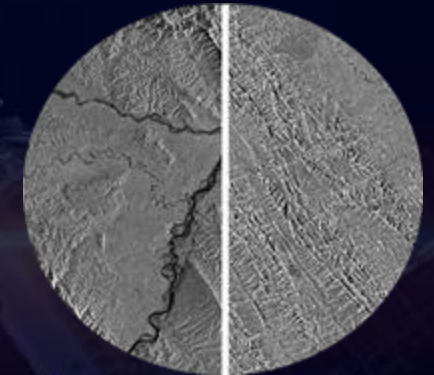

VISIBLE SATELLITE IMAGERY

BANDS:- RED, GREEN, BLUE,
NEAR INFRARED

THERMAL INFRARED DATA

BANDS:- MEDIUM WAVE
INFRARED, LONG WAVE
INFRARED

SAR DATA

SYNTHETIC APERTURE RADAR

- **Satleo** will capture the **world's first (Visible -R, G, B, NIR + Thermal - MWIR+LWIR) high-resolution**, co-registered visible and thermal imagery, enabling advanced data fusion for powerful, actionable insights.

Who We Are

Satleo Labs is a space-tech company delivering high-precision **thermal intelligence** from orbit.

Our **microsatellites scan** the Earth in **MWIR, LWIR, and visible bands**, capturing thermal variations with 1° Kelvin accuracy, processed through onboard AI and edge computing.

From agriculture to defense, we enable smarter, faster, and more sustainable decisions from space.



ENABLING INTELLIGENCE FROM SPACE

Supporting mission-critical defense operations with near real-time thermal data.



Surveillance and Target Detection

Monitor movements and activities of large-size establishments, even in darkness or under camouflage



Early Warnings & Situational Awareness

Monitor strategic sites like airbases and missile silos for thermal anomalies and operational patterns.



Covert Operations & Reconnaissance

Detect underground hideouts, suspect movements, and heat variations in concealed areas.



Border & Maritime Surveillance

Track convoys or AIS-off large vessels using thermal emissions.



Military Infrastructure Monitoring

Assess bases, hangars, and depots for unusual thermal activity.



Tunnel & Subsurface Detection

Identify hidden tunnels or underground facilities through long-term ground temperature analysis.



Conflict & Disaster Zones

Locate survivors, assess thermal risks, and monitor real-time conflict activity.

The **Satleo** Products

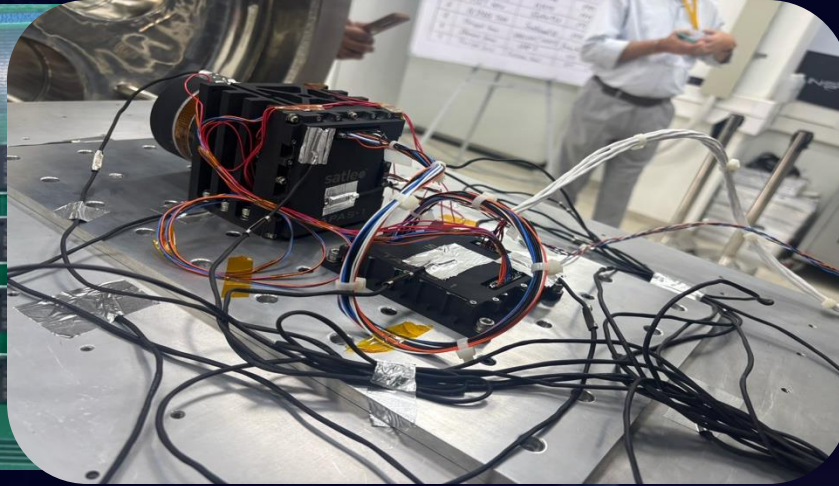

TAPAS -1

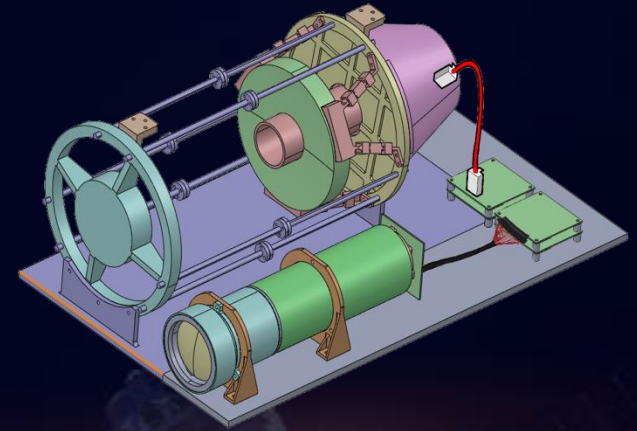

PYRO-1

Satleo Satellite Manufacturing Facility



Monitoring of Nuclear Facility Using Thermal Data

15 September, 2025

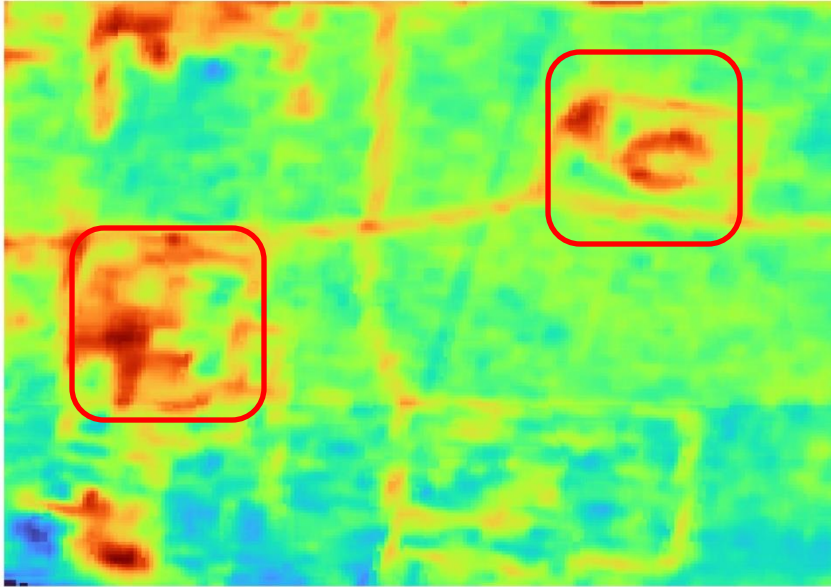

1 October, 2025

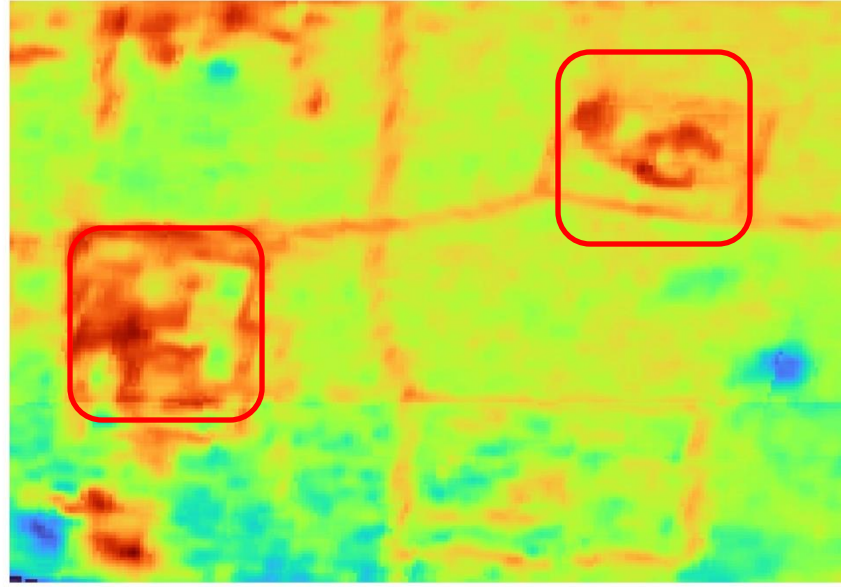

08 April, 2025

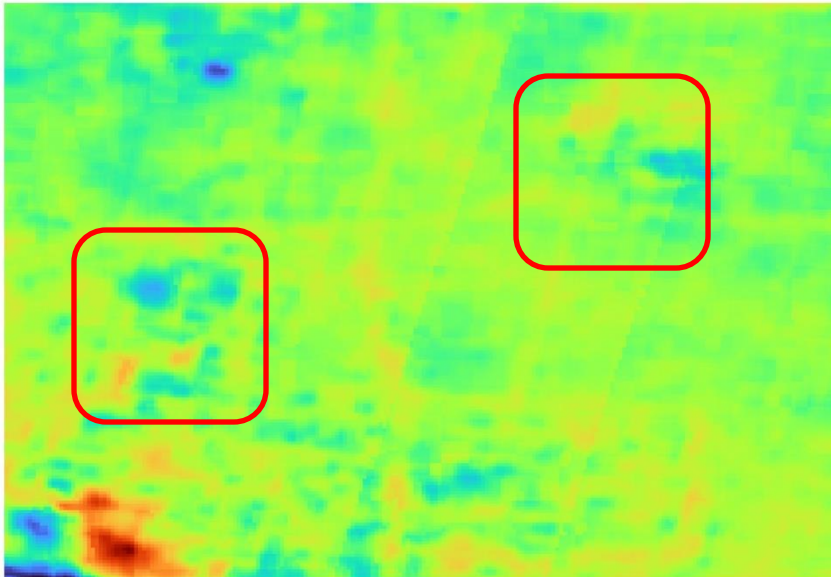

02 November, 2025

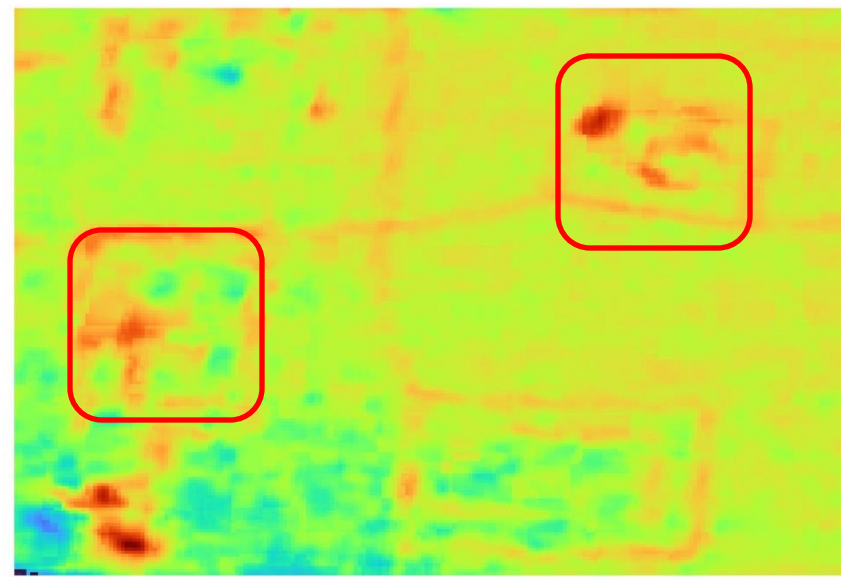

Operational

Non-Operational

Let's **Talk**



shravan@satileolabs.com



www.satileolabs.com

Let's build smarter, see deeper, and act faster—together.

